

Non U.S. Events (MRO Asia-Pacific, MRO Europe)

Shell scheme refers to a pre-built structure that is provided by the show organizer. It is part of a package of benefits.

Contents and furnishing of the shell scheme booth can not exceed the height of the shell scheme structure and custom builds are NOT permitted. Carpet is provided by the organizer.

SHELL SCHEME GENERAL GUIDELINES

- ALL internal stand fitting and displays are contained within the shell scheme structure and do not exceed 2.5 meters in height.
- No display materials or logos may be fixed to the shell scheme fascia panel. No fixings may be made to the walls by piercing or screwing anything onto the panels or beams.
- Exhibitors may affix lightweight photographs and technical information sheets etc. direct to the shell scheme walls with good quality double-sided adhesive pads or similar, provided such material can be removed without damage to the wall panels, any damage made to the panels will result in a charge.
- Exhibitors that purchase stands as shell scheme are not permitted to remove the shell scheme and build their own structures. Raw spaces booths are a minimum of 18sqm.

Fascia

The fascia is the name board sits at the top of your stand and will carry your Company Name and Stand Number

Removing Fascia and Gridwork

- The fascia and/or gridwork can only be removed from your booth with permission from show management.
- Show management will determine if removal is possible based on location and structural integrity of the adjoining booths
- All companies removing fascia and/or gridwork MUST submit plans for approval from show management
- No shell scheme booth can exceed the 2.5 meter height limit regardless of whether or not fascia and gridwork have been removed. This includes signage, furnishings, lights, etc.

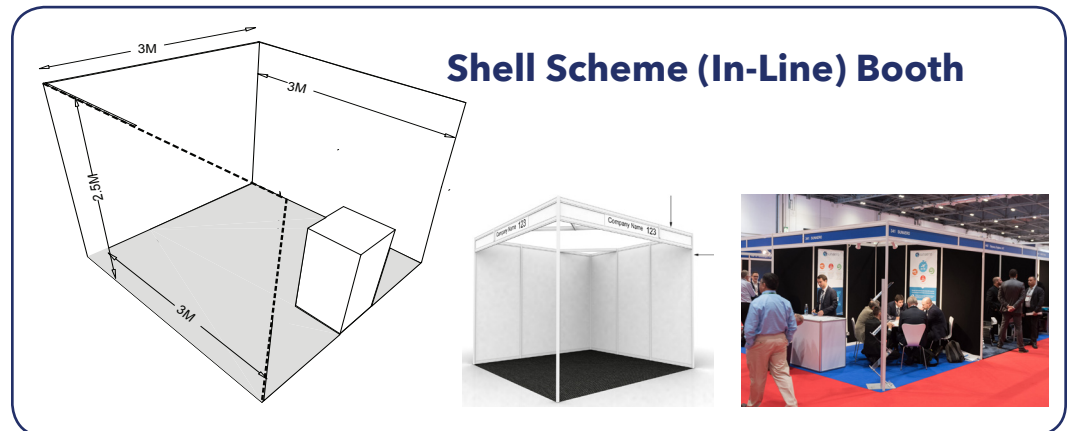

SHELL SCHEME (IN-LINE) BOOTH (Min 9sqm)

- Arranged in a straight line
- Has neighbors on either side (in-line)
- One side exposed to aisle (in-line)
- Two sides exposed to aisle (corner)
- Maximum back wall height is 2.5m
- Hanging signs are not permitted
- Shell scheme framework cannot be removed

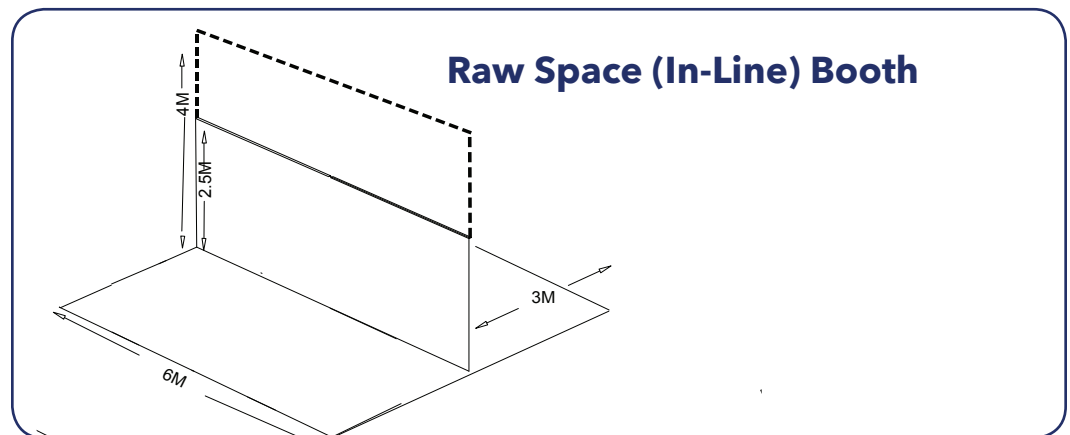

RAW SPACE (IN-LINE) BOOTH (Min 18sqm)

- Arranged in a straight line, or back-to-back with a neighbor (a 36 sqm island split into two 18sqm booths)
- Has neighbors on either side
- One side exposed to aisle (in-line)
- Two or three sides exposed to aisle (corner)
- Maximum back wall height is 2.5 meters, can go up to 4 m with show management permission
- Design must include a solid wall separating booth from adjacent booth. Wall must measure complete length of the booth and be 2.5m high (can go up to 4m with show management permission)
- Back wall must be cleanly "finished" and painted.
- Hanging signs are not permitted
- All raw space booth plans must be approved by show management.

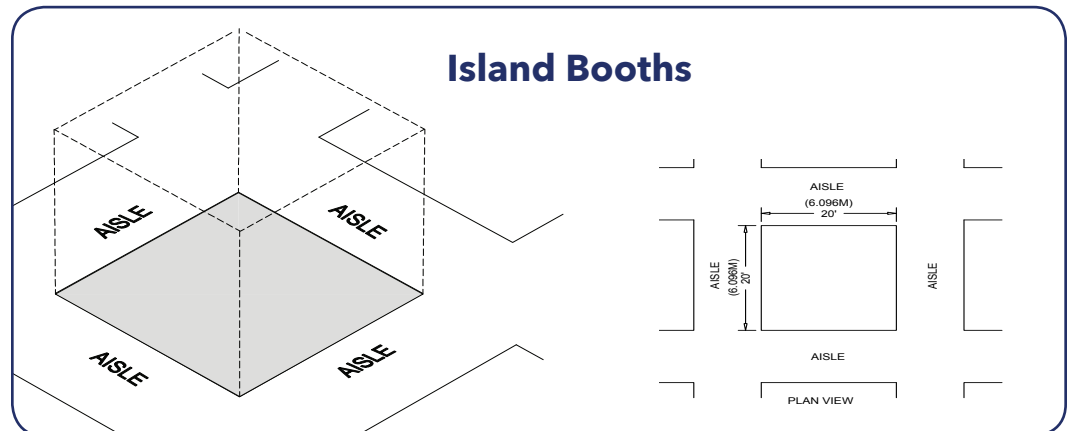

Island Booths

- Any size booth exposed to aisles on all four sides
- Hanging Signs permitted. Rigging must be completed by official contractor.
- The entire cubic content of the space may be used up to the maximum allowable height, which is 4 meters, or 6 meters with Show Management's approval including signage.
- All raw space booth plans must be approved by show management. Please send all schematics with elevations/ materials used to allison.gold@aviationweek.com.
- Additional approvals and guidelines may be required by the venue.

Submitting plans for approval

1. Submission of information should be in the form of drawings and calculations, not photographs or rough sketches, as it is not possible to assess the structure without details of the stand.
- 2. Plans that do not include all elevations will not be accepted**
3. Drawings should contain enough detail to show exactly how the stand will be constructed including baseplates, joint construction support details etc.
4. Calculations are to prove that the stand is stable and capable of supporting the loads of anything which will be supported i.e.: lights, speakers plasma screens etc. A nominal load should be applied for wind (0.15 kN/m²) although this appears not to apply in the halls stands have been affected by doors being open. A calculation should also be carried out for overturning this assumed to be the impact of a person (0.75 kN) at a height of 1.5m above the ground.
5. No fixing is allowed into the hall floor at these venues, other means of securing the stands need to be considered.
6. Failure to submit your designs may result in an inability to exhibit.

Towers (free-standing exhibit component separate from the main exhibit fixture)

- height restriction is the same as applies to the exhibit space configuration

Multi-story Exhibits

- Display fixture includes two or more levels
- Multi-story Exhibit requires prior approval by the exhibit facility, and/or relevant local government agency and show management and will have additional fees applied by show management and/or local health and safety organization
- For more information about adding a second story and the approval process, please contact Allison Gold at Allison.gold@aviationweek.com, +1.646.233.4425

General Decorating Guidelines

- Any portion of a display that extends above or beyond that of the booth adjoining to the rear or side must be finished with paint or drape at the Exhibitor's expense. Any portion of an Exhibitor's booth facing an aisle must be finished.
- Drip pans and scrap buckets should be provided for operating machinery to prevent lubricants, paints, etc., from staining the floor causing a slippage hazard.
- Painting may be done inside the exhibit hall as long as drop cloths are used to prevent any damage to the building. No spray painting is permitted inside the exhibit halls. Spray painting may be done outside as long as drop cloths are used to prevent any damage to sidewalk, dock, grass, buildings, etc.
- Paint must be removed nightly and all cans must be tightly closed to prevent their contents from staining the floor, causing a slippage hazard, and tracking of paint, etc., over another Exhibitor's carpet.
- Exhibitors are liable for any damage they cause (or third party authorized by them) to the walls, floors, columns, doors, windows, etc., during the installation, operating and dismantling of their exhibits.

Lighting

- Exhibitors must adhere to the following suggested minimum guidelines when determining booth lighting:
 - o No lighting, fixtures, lighting trusses, or overhead lighting are allowed outside the boundaries of the exhibit space. Exhibitors intending to use hanging light systems must submit drawings to exhibition management for approval.
 - o Lighting, including gobos, must be directed to the inner confines of the booth space. Lighting should not project onto other exhibits or exhibition aisles.
 - o Lighting which is potentially harmful, such as lasers or ultraviolet lighting, must comply with facility rules and be approved in writing by exhibition management.
 - o Lighting that spins, rotates, pulsates, and other specialized lighting effects must be in good taste and not interfere with neighboring Exhibitors or otherwise detract from the general atmosphere of the event.
 - o Currently some convention facilities are not allowing quartz halogen lighting fixtures in exhibits due to potential fire hazards. Check with exhibition management.
 - o Reduced lighting for theater areas must be approved by the exhibition organizer, the utility provider, and the exhibit facility.

Carpeting

- The use of carpeting or other professional floor covering is required by each Exhibitor. These floor coverings must not be sealed to the floors in such a manner as to injure the floor or be so installed as to be a hazard to public safety or as to endanger the public. Exhibitors are responsible for the final condition of the floor in their space. The edges of raised flooring may be inclined, providing the slope is gradual and gentle.
- If an exhibitor sets his booth without floor covering, carpet will be ordered at the exhibitor's expense.
- If exhibitor will be setting up late and is bringing their own carpet, they must notify show management or carpet will be ordered at exhibitor's expense.

Americans with Disabilities Act (ADA)

All exhibiting companies are required to be in compliance with the Americans with Disabilities Act (ADA), and are encouraged to be sensitive, and as reasonably accommodating as possible, to attendees with disabilities. Information regarding ADA compliance is available from the U.S. Department of Justice ADA Information Line (800) 514-0301, and from the ADA website at www.ada.gov.

Some examples of how to design an exhibit for ADA compliance:

- Make exhibits wheelchair accessible by ramping raised exhibit flooring without extending a ramp into the aisle. Note: a standard wheelchair ramp should have a grade no steeper than 1:12. This means that for every inch of rise (change in height), there should be 12 inches of run (change in length)
- Ramp the entry or use hydraulic lifts to trailer exhibits
- Avoid double-padded plush carpet to ease mobility device navigation
- Provide the same attendee experience on both levels of a two-story exhibit
- Offer a signer or other auxiliary hearing-impaired apparatus for sound presentations or have a printed copy of the presentation available

- Run an audio presentation for people with sight problems
- Arrange touch screen displays at a height to accommodate a person sitting in a wheelchair

To avoid heavy fines by the U. S. Department of Justice, exhibitors must adhere to the ADA rules. Exhibits are not exempt from ADA compliance.

Structural Integrity

All exhibit displays should be designed and erected in a manner that will withstand normal contact or vibration caused by neighboring exhibitors, hall laborers, or installation/dismantling equipment, such as fork lifts. Displays should also be able to withstand moderate wind effects that may occur in the exhibit hall when freight doors are open. Refer to local building codes that regulate temporary structures.

Flammable and Toxic Materials

All materials used in display construction or decorating should be made of fire retardant materials and be certified as flame retardant. Samples should also be available for testing. Materials that cannot be treated to meet the requirements should not be used. A flame-proofing certificate should be available for inspection. Exhibitors should be aware of local regulations regarding fire/safety and environment which must be adhered to.

Exhibitors should dispose of any waste products they generate during the exhibition in accordance with guidelines established by the Environmental Protection Agency and the facility.

Storage

Fire regulations in most exhibit facilities prohibit storing product, literature, empty packing containers, or packing materials behind back drapes or under draped tables. In most cases, however, exhibitors may store a limited supply of literature or product appropriately within the booth area, so long as these items do not impede access to utility services, create a safety problem, or look unsightly.

Booth Design/EAC/Contractors/Display Rules Exhibitor Appointed Contractors (EACs)

Exhibitor Appointed Contractors (EACs)/Stand Builders

An Exhibitor Appointed Contractor (EAC) is any company other than Aviation Week's official service contractors. Exhibitors are responsible for informing all appointed contractors of the rules, requirements and regulations and for ensuring their compliance. Any and all outside vendors must fulfill the following requirements.

Any exhibitor must insure that non-official vendors hired to perform any of the following services at Aviation Week's event must comply with the rules, requirements and regulations.

- Audio Visual
- Carpet Rental / Flooring
- Computer Rentals
- Exhibit Rental/Booth Rental
- Exhibitor Marketing
- Floral
- Furniture
- Installation & Dismantling / Display Labor / Supervision
- Personnel / Temporary Help / Models
- Photography / Video / Film
- Security / Guard Service
- Transportation / Freight Carrier

Note: for electrical, plumbing, internet, telephone, cleaning, drayage, rigging - the exhibitor and/or EAC must utilize the official vendor designated by Aviation Week.

If an exhibitor plans to use a firm other than the "Official Show Vendor", please fill out the Aviation Week Exhibitor Appointed Contractor form (EAC). The form can be found here: <https://fs2.formsite.com/AW-Events/form58/index.html>

This form must be completed and returned to Aviation Week no later than four (4) weeks prior to the event.

Important Notes:

- EACs should supply a list of all full-time employees who will be installing, dismantling or working in the exhibiting company's booth. Aviation Week management also requires that exhibitor appointed contractors furnish a list of all subcontractors they will use during installation, show days and dismantling. Any company that is not an approved exhibitor appointed contractor or does not appear on an appointed exhibitor contractor's list of approved subcontractors will be denied access to the show floor. Exhibitor appointed contractors must collect the proper COIs from their subcontractor(s), and maintain the original certificates (photocopies and faxes are not acceptable) on file for review by Aviation Week management.
- During the build-up and breakdown periods, the exhibition is only accessible with a valid access badge. This also applies to stand builders and/or suppliers. This policy is implemented in order that we know exactly who is present in the hall and can act appropriately should an emergency situation arise.

Rules for rigging:

- Rigging is only allowed above your own stand to the maximum height. Maximum height is 20' (with Show Management's permission) at the top of the sign.
- Rigging Plots must be submitted in advance by the exhibitor. These plots must show the location of the hang points, the height above the floor of the hang points, and the weight of each point. In addition the plot must show the booth outline with the front aisle for reference.
- Hanging anchor points must be pre-fabricated and ready for use. If any hang point supports over 250 lbs., please notify Rigging company immediately for special authorization.
- Electric signs must be in working order and in accordance with the National Electrical Code.
- ELECTRICAL SERVICE requirements for hoists and electric signs must be ordered in advance from the facility.